

data referred to : Water, pure [100%] ; 20°C; 0,9983kg/dm³; 1,001mm²/s

Tolerances acc. ISO 9906 Annex A

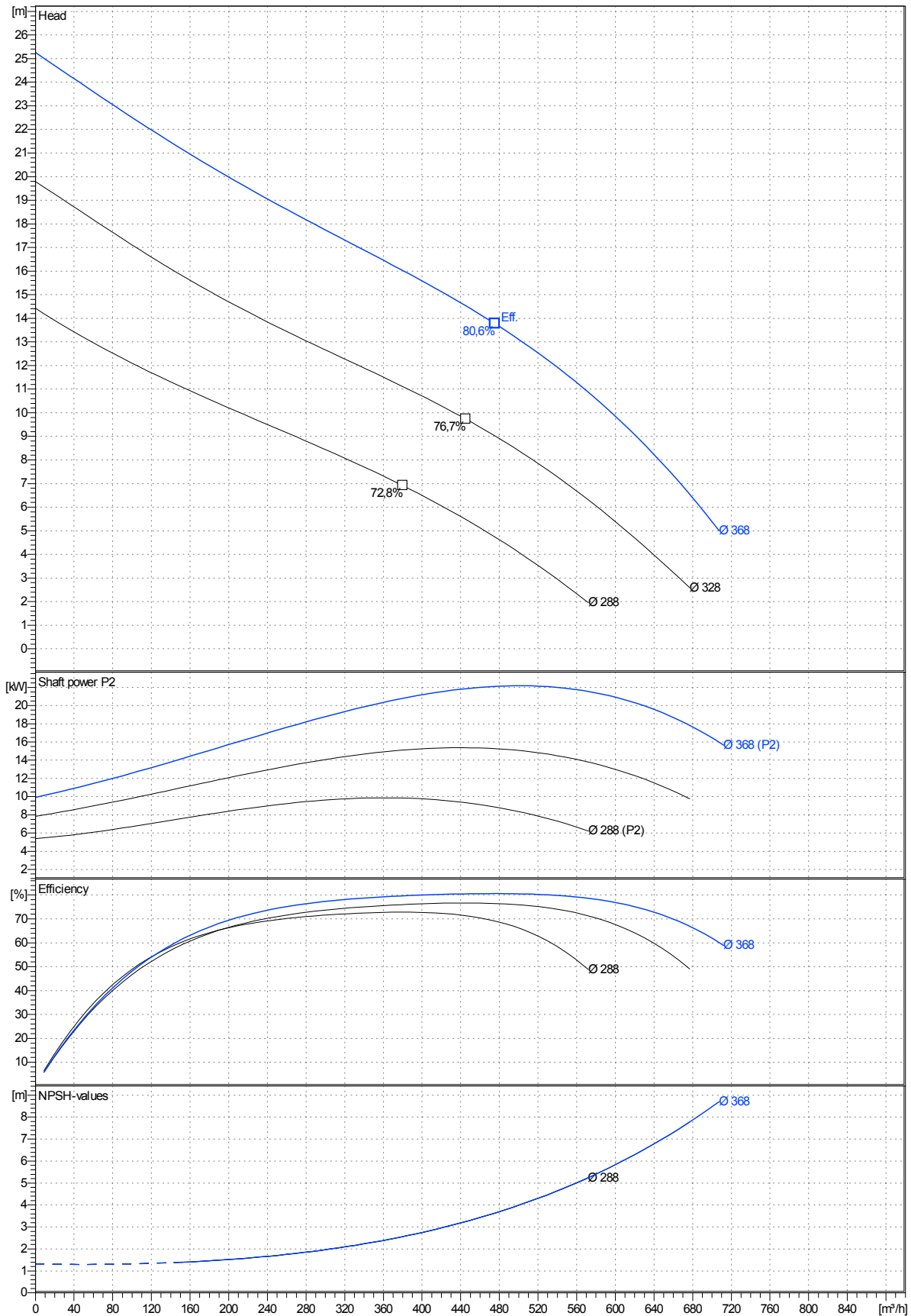

Curves are approximate, pump is guaranteed for one set of conditions (capacity, head, efficiency).

Submersible, centrifugal, non-clogging sewage pump PX4-200.0-6 CHANNEL 1 capable of handling raw,unscreened sewage.

The pump can be capable of operating continuously in submersed or dry installed condition due the internal cooling system (standard version).

An internal impeller, fitted between the mechanical shaft seal, circulate a cooling liquid (Ecoflu) in a closed loop through a cooling jacket, and transfer the heat to the pumped liquid by a cooling flange (heat exchange).

The pumps manufactured within European Union with the latest manufacturing and environmental standards and practical standard features as :

-Electrical motor PXFLOW -SIEMENS with highest energy saving norm EFF1 have Class F insulation (rated for 155 degrees Celsius)as standard (Class H as option),three thermal overload switches, one per phase, internally wound to combat high temperature loads.

-Built-in moisture sensors

-Dual channel impeller made in ductile iron GGG40 are of non clogging design

-Channel and vortex impellers can be accommodated in the same volute. This advance together with possibility to be trimmed allow to meet changing duties.

-Rotor shaft oversized made in stainless steel and oversized ball bearings ensuring smooth and vibration free running with extended life time as result.

-Shaft sealing system consist of double mechanical seals built into a replaceable cartridge facilitate quick changes even on-site without special tools.

-Wear rings with 'reducer' clearances system allow to be re-positioned axially in order to reduce the clearances between the channel impeller and volute.

-Fast lock connection system latch bolts made in stainless steel for easy removal of the motor together with impeller from the volute.

Materials

Motor housing, volute :cast iron GG -25

Impeller: ductile iron GGG40

Shaft, cartridge sleeve :stainless steel 431

Shaft seal:Media side sic/sic
Cooling side sic/sic

Bearings:upper:single row deep groove ball bearing
lower: double single angular contact ball bearing

PX4-200.0-6 CHANNEL 1 with motor M4.2-30 / 6

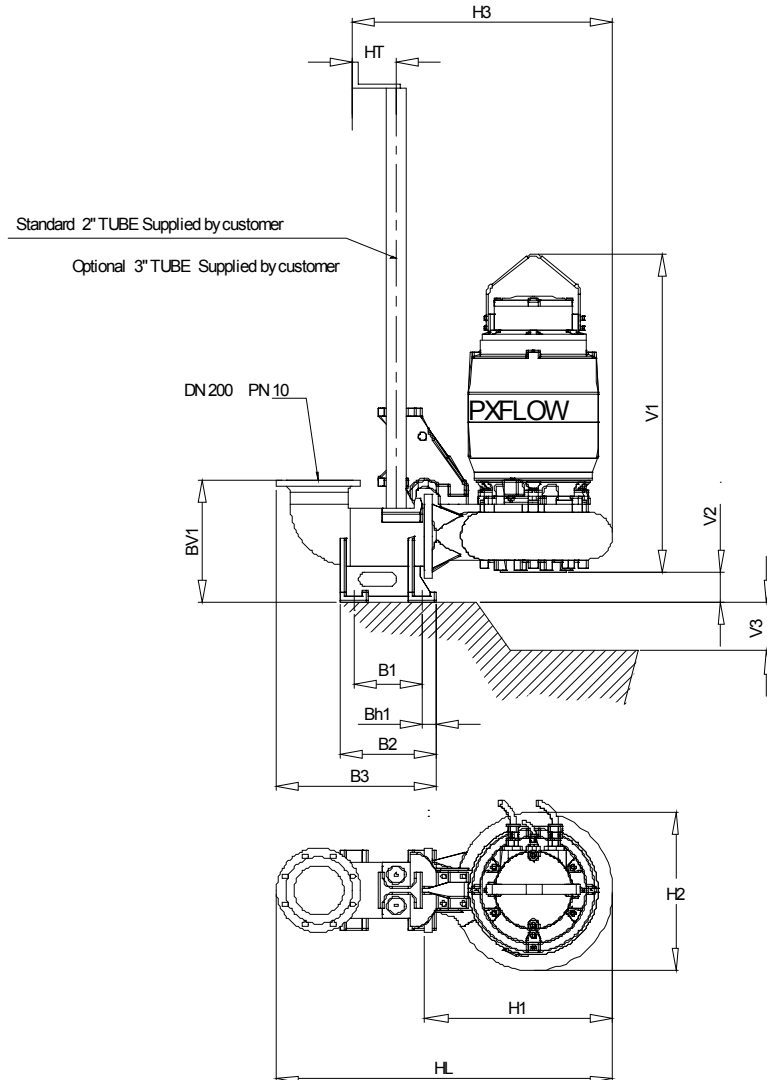

Dimensions	mm	Dimensions	mm
B1	280		
B2	380		
B3	600		
Bh1	50		
BV1	450		
H1	740		
H2	570		
H3	955		
HL	1335		
HT	90		
V1	1287		
V2	90		
V3	100		

For Discharge connection bracket :
 Outlet flange - Standard : DN200 / PN10
 - Option : 8" ANSI class 125

For pump :
 Outlet flange - Standard : DN200 / PN10
 - Option : 8" ANSI class 125

Suction flange - Standard : DN200 / PN10
 - Option : 8" ANSI class 125

Weight of Pump with cooling jacket = 725 kg
 (without cooling jacket : - 125 kg)
 Weight of Adapter = 33 kg

PX4-200.0-6 CHANNEL 1 with motor M4.2-30 / 6

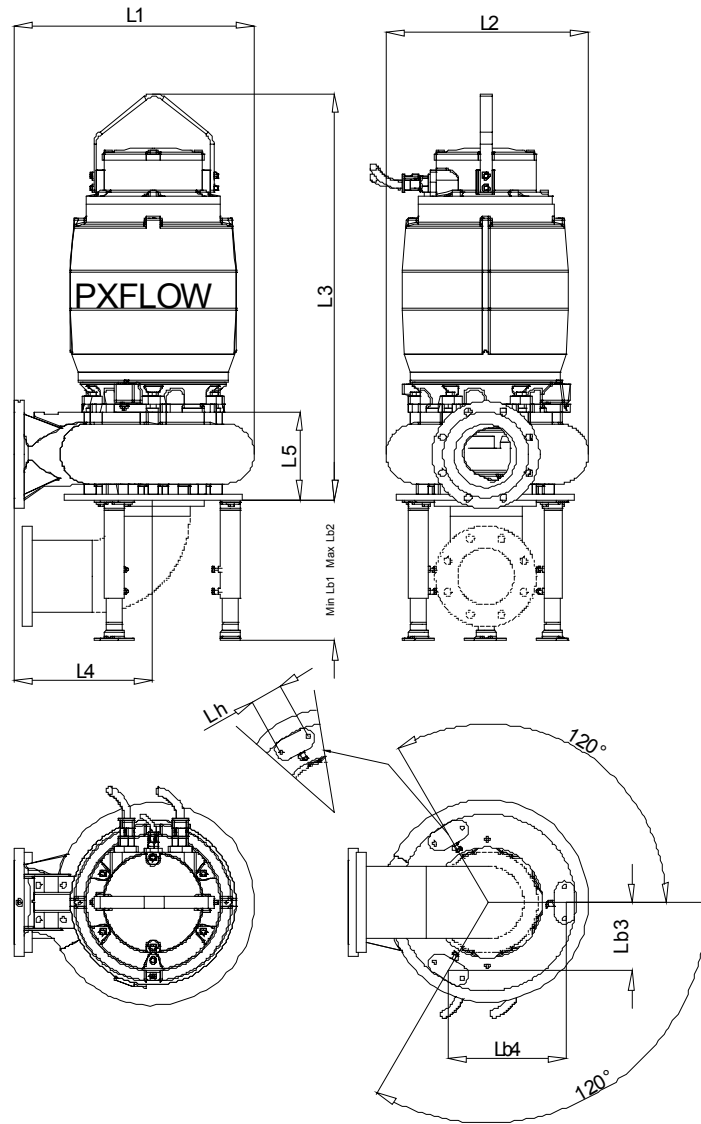

Dimensions	mm	Dimensions	mm
L1	740		
L2	570		
L3	1287		
L4	440		
L5	277		
Lb1	550		
Lb2	800		
Lb3	216		
Lb4	375		
Lh	100		

Outlet flange - Standard : DN200 / PN10
 - Option : 8" ANSI class 125

Suction flange - Standard : DN200 / PN10
 - Option : 8" ANSI class 125

Weight of Pump with cooling jacket = 725 kg
 Weight of Adjustable Legs = 0 kg

PX4-200.0-6 CHANNEL 1 with motor M4.2-30 / 6

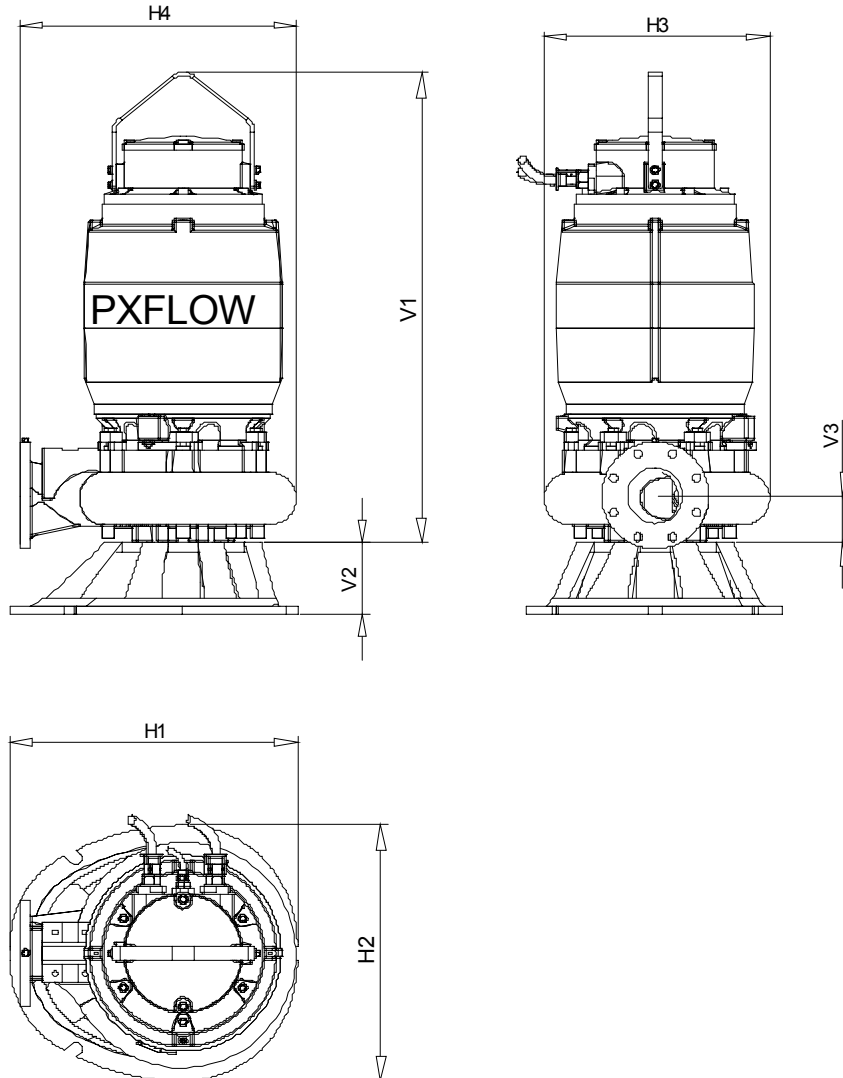

Dimensions	mm	Dimensions	mm
H1	650		
H2	550		
H3	570		
H4	740		
V1	1462		
V2	175		
V3	142		

Outlet for hose - Option : Ø 200mm (8")

For pump :
 Outlet flange - Standard : DN200 / PN10
 - Option : 8" ANSI class 125

Suction flange - Standard : DN200 / PN10
 - Option : 8" ANSI class 125

Weight of Pump with cooling jacket = 725 kg
 (without cooling jacket : - 125 kg)
 Weight of Base for Transportable = 34 kg