

data referred to : Water, pure [100%] ; 20°C; 0,9983kg/dm³; 1,001mm²/s Tolerances acc. ISO 9906 Annex A

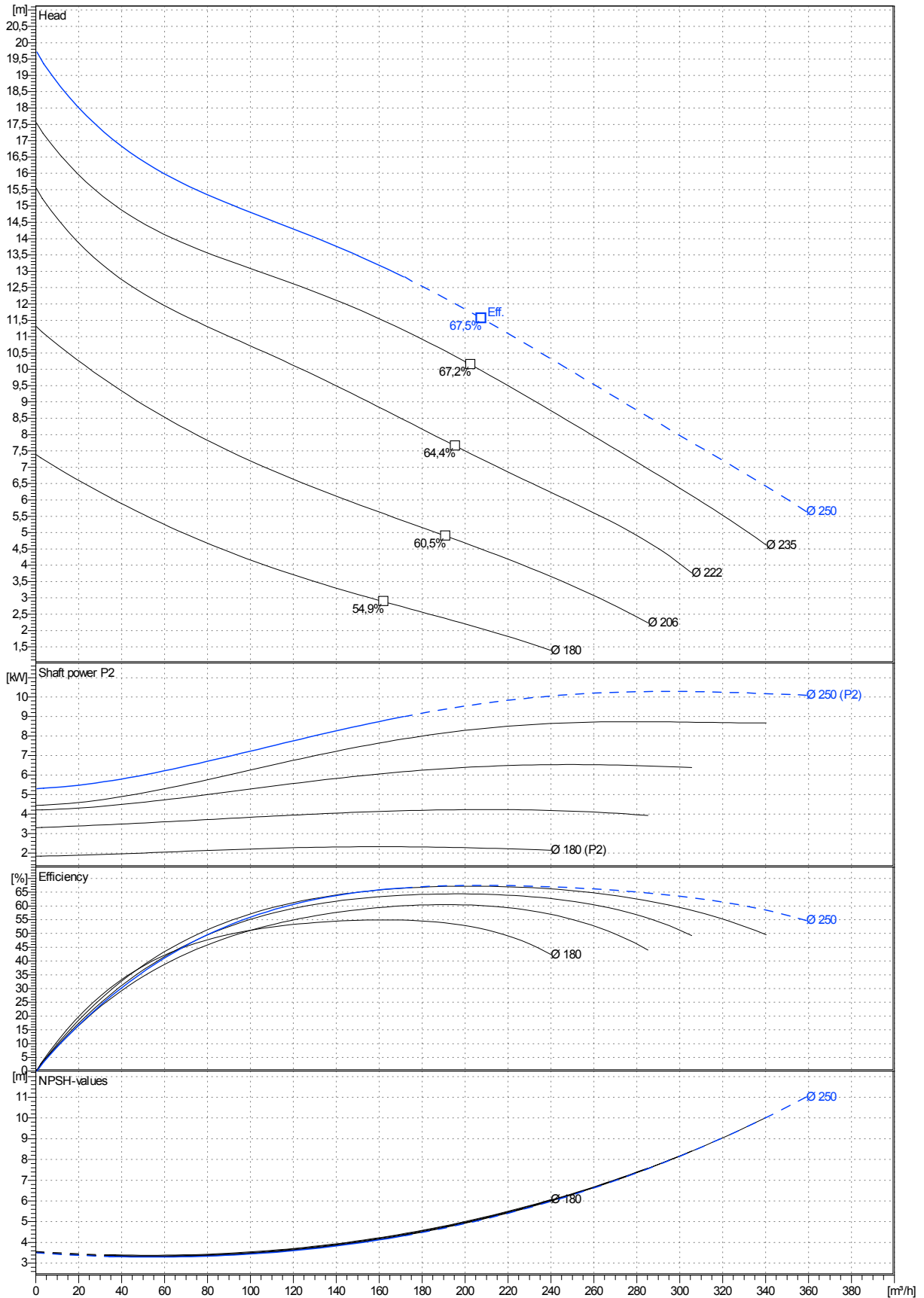

Curves are approximate, pump is guaranteed for one set of conditions (capacity, head, efficiency).
PAPANTONATOS reserves the right to modify any data without prior notice.

Submersible, centrifugal, non-clogging sewage pump PX2-150.0-4 CHANNEL 1 capable of handling raw,unscreened sewage.

The pump can be capable of operating continuously in submersed or dry installed condition due the internal cooling system (standard version).

An internal impeller, fitted between the mechanical shaft seal, circulate a cooling liquid (Ecoflu) in a closed loop through a cooling jacket, and transfer the heat to the pumped liquid by a cooling flange (heat exchange).

The pumps manufactured within European Union with the latest manufacturing and environmental standards and practical standard features as :

-Electrical motor PXFLOW -SIEMENS with highest energy saving norm EFF1 have Class F insulation (rated for 155 degrees Celsius)as standard (Class H as option),three thermal overload switches, one per phase, internally wound to combat high temperature loads.

-Built-in moisture sensors

-Dual channel impeller made in ductile iron GGG40 are of non clogging design

-Channel and vortex impellers can be accommodated in the same volute. This advance together with possibility to be trimmed allow to meet changing duties.

-Rotor shaft oversized made in stainless steel and oversized ball bearings ensuring smooth and vibration free running with extended life time as result.

-Shaft sealing system consist of double mechanical seals built into a replaceable cartridge facilitate quick changes even on-site without special tools.

-Wear rings with 'reducer' clearances system allow to be re-positioned axially in order to reduce the clearances between the channel impeller and volute.

-Fast lock connection system latch bolts made in stainless steel for easy removal of the motor together with impeller from the volute.

Materials

Motor housing, volute :cast iron GG -25

Impeller, adapter: ductile iron GGG40

Shaft, cartridge sleeve :stainless steel 431

Shaft seal:Media side sic/sic
Cooling side sic/carbon

Bearings:upper:single row deep groove ball bearing
lower: double angular contact ball bearing

data referred to : Water, pure [100%] ; 20°C; 0,9983kg/dm³; 1,001mm²/s

Tolerances acc. ISO 9906 Annex A

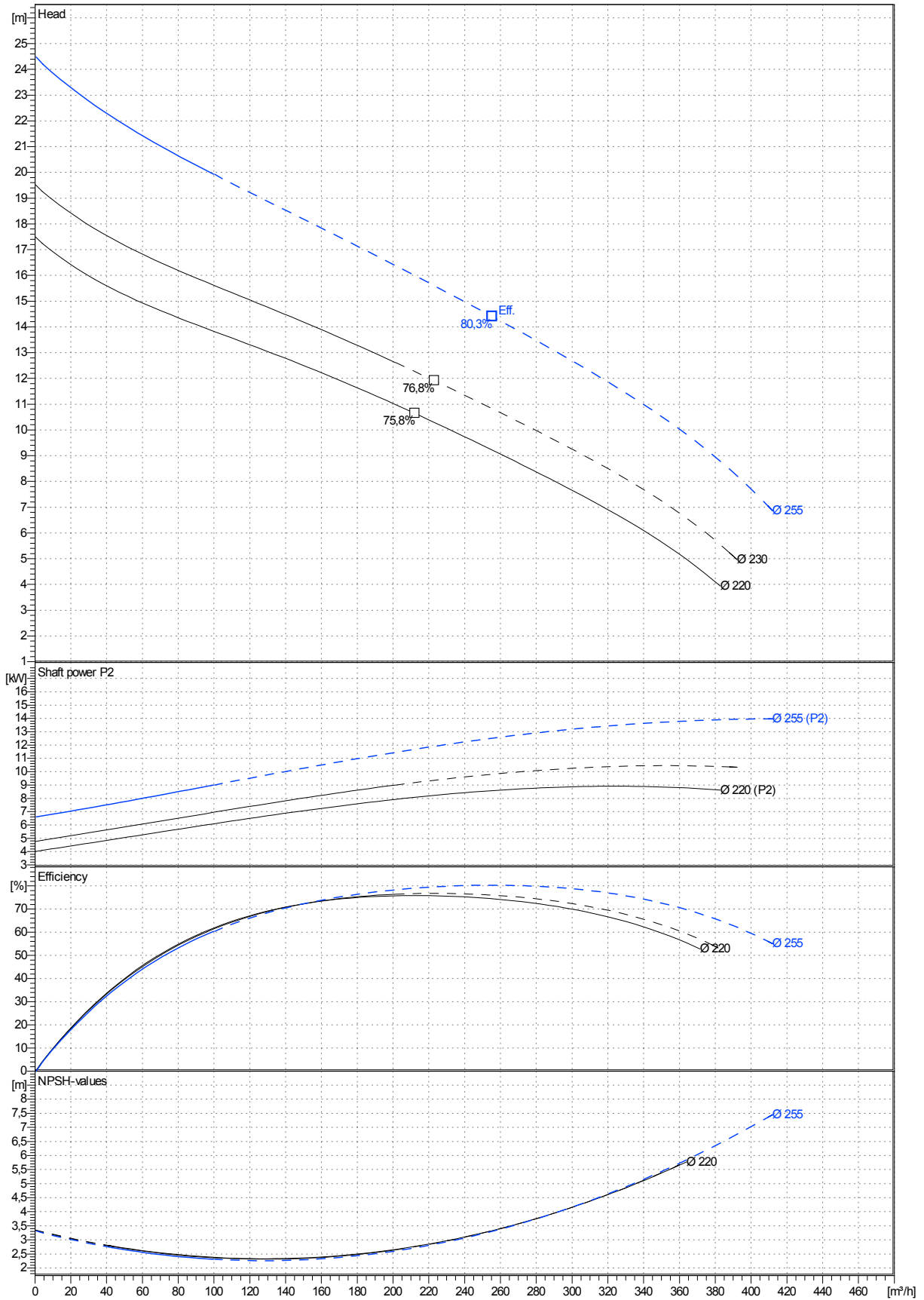

Curves are approximate, pump is guaranteed for one set of conditions (capacity, head, efficiency).

Submersible, centrifugal, non-clogging sewage pump PX2-150.0-4 CHANNEL 2 capable of handling raw,unscreened sewage.

The pump can be capable of operating continuously in submersed or dry installed condition due the internal cooling system (standard version).

An internal impeller, fitted between the mechanical shaft seal, circulate a cooling liquid (Ecoflu) in a closed loop through a cooling jacket, and transfer the heat to the pumped liquid by a cooling flange (heat exchange).

The pumps manufactured within European Union with the latest manufacturing and environmental standards and practical standard features as :

-Electrical motor PXFLOW -SIEMENS with highest energy saving norm EFF1 have Class F insulation (rated for 155 degrees Celsius)as standard (Class H as option),three thermal overload switches, one per phase, internally wound to combat high temperature loads.

-Built-in moisture sensors

-Dual channel impeller made in ductile iron GGG40 are of non clogging design

-Channel and vortex impellers can be accommodated in the same volute. This advance together with possibility to be trimmed allow to meet changing duties.

-Rotor shaft oversized made in stainless steel and oversized ball bearings ensuring smooth and vibration free running with extended life time as result.

-Shaft sealing system consist of double mechanical seals built into a replaceable cartridge facilitate quick changes even on-site without special tools.

-Wear rings with 'reducer' clearances system allow to be re-positioned axially in order to reduce the clearances between the channel impeller and volute.

-Fast lock connection system latch bolts made in stainless steel for easy removal of the motor together with impeller from the volute.

Materials

Motor housing, volute :cast iron GG -25

Impeller, adapter: ductile iron GGG40

Shaft, cartridge sleeve :stainless steel 431

Shaft seal:Media side sic/sic
Cooling side sic/carbon

Bearings:upper:single row deep groove ball bearing
lower: double angular contact ball bearing

PX2-150.0-4 CHANNEL 1 with motor M2.2- 9,0 / 4

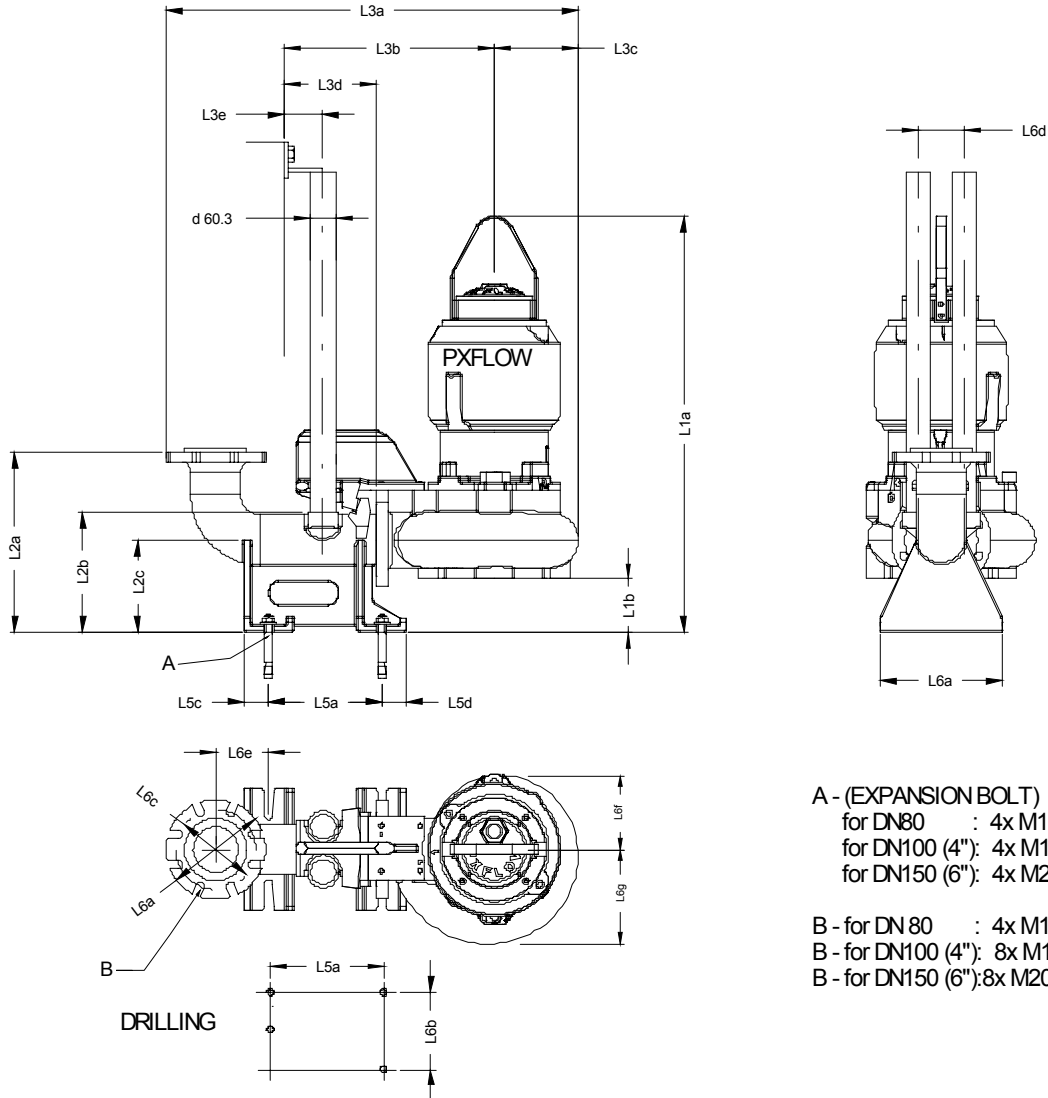

A - (EXPANSION BOLT)
 for DN80 : 4x M12x120
 for DN100 (4"): 4x M16x140 (5/8"x5.5")
 for DN150 (6"): 4x M20x200

B - for DN80 : 4x M16
 B - for DN100 (4"): 8x M16 (5/8")
 B - for DN150 (6"): 8x M20

DRILLING

Dimensions	mm	Dimensions	mm
L1a	967	L5d	60
L1b	151	L6a	320
L2a	455	L6b	285
L2b	354	L6c	240
L2c	250	L6d	100
L3a	1062	L6e	100
L3b	505	L6f	190
L3c	224	L6g	252
L3d	205		
L3e	90		
L3f	395		
L5a	280		
L5b	220		
L5c	40		

For Discharge connection bracket :
 Outlet flange - Standard : DN150 / PN10
 - Option : 6" ANSI class 125

For pump :
 Outlet flange - Standard : DN150 / PN16
 - Option : 6" ANSI class 125

Suction flange - Standard : DN150 / PN16
 - Option : 6" ANSI class 125

Weight of Pump with cooling jacket = 181 kg
 (without cooling jacket : - 20 kg)
 Weight of Adapter = 10 kg

PX2-150.0-4 CHANNEL 1 with motor M2.2- 9,0 / 4

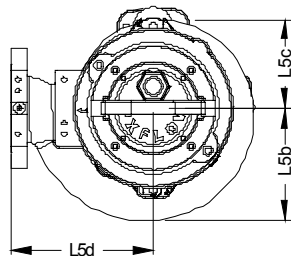
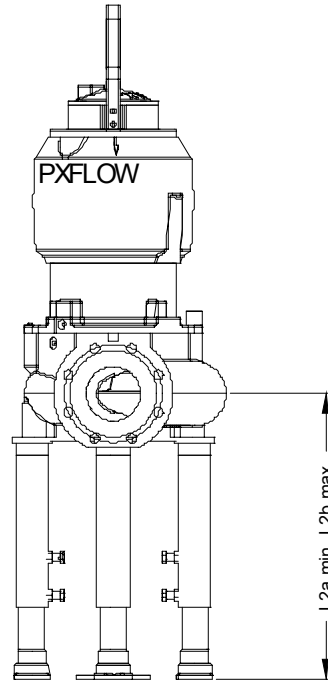
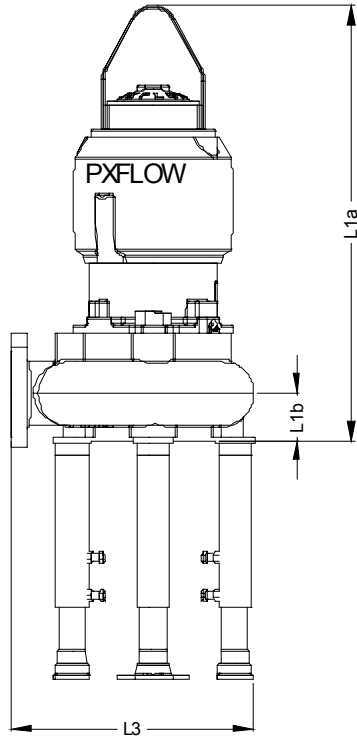

Standard
DN150 PN16
8xM20

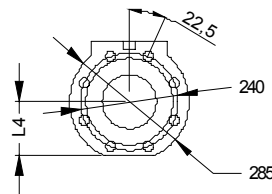

Option
6" class 125
8xM20

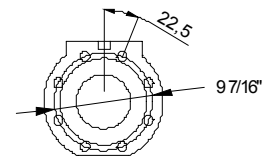

Dimensions	mm	Dimensions	mm
L1a	840		
L1b	119		
L2max	317		
L2min	450		
L3	586		
L4	130		
L5b	266		
L5c	245		

Outlet flange - Standard : DN150 / PN16
- Option : 6" ANSI class 125

Suction flange - Standard : DN150 / PN16
- Option : 6" ANSI class 125

Weight of Pump with cooling jacket = 181 kg
Weight of Adjustable Legs = 6,1 kg

PX2-150.0-4 CHANNEL 1 with motor M2.2- 9,0 / 4

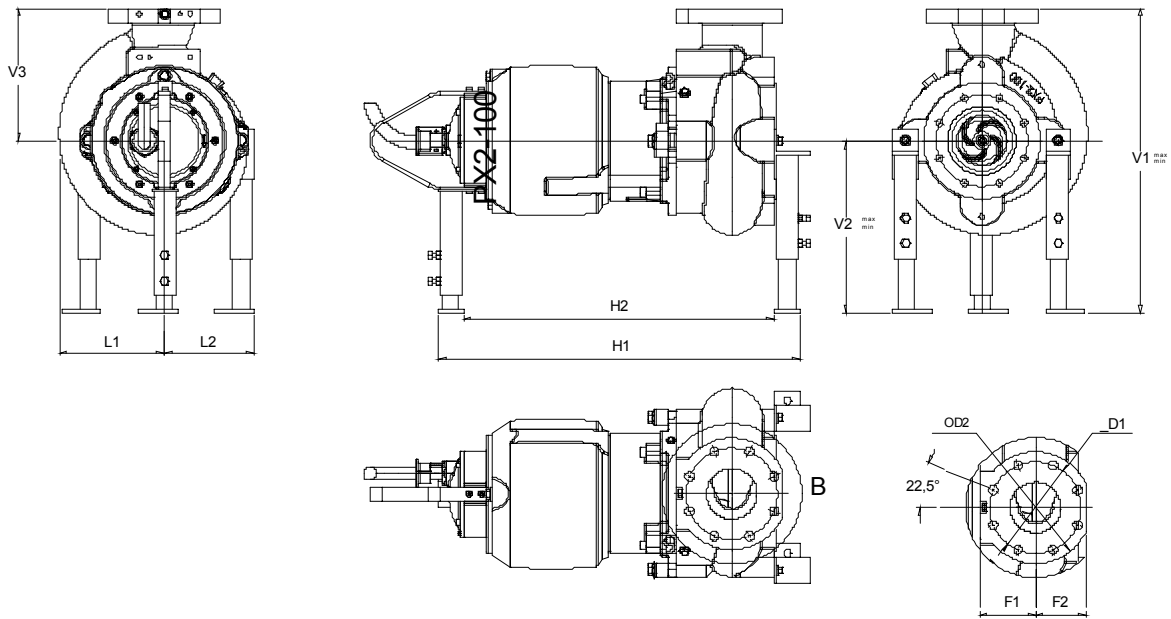

Dimensions	mm	Dimensions	mm	
L1a	967	L5d	60	Outlet flange - Standard : DN150 / PN16 - Option : 6" ANSI class 125 Suction flange - Standard : DN150 / PN16 - Option : 6" ANSI class 125 Weight of Pump with cooling jacket = 181 kg Weight of Adjustable Legs = 0 kg
L1b	151	L6a	320	
L2a	455	L6b	285	
L2b	354	L6c	240	
L2c	250	L6d	100	
L3a	1062	L6e	100	
L3b	505	L6f	190	
L3c	224	L6g	252	
L3d	205			
L3e	90			
L3f	395			
L5a	280			
L5b	220			
L5c	40			

PX2-150.0-4 CHANNEL 1 with motor M2.2- 9,0 / 4

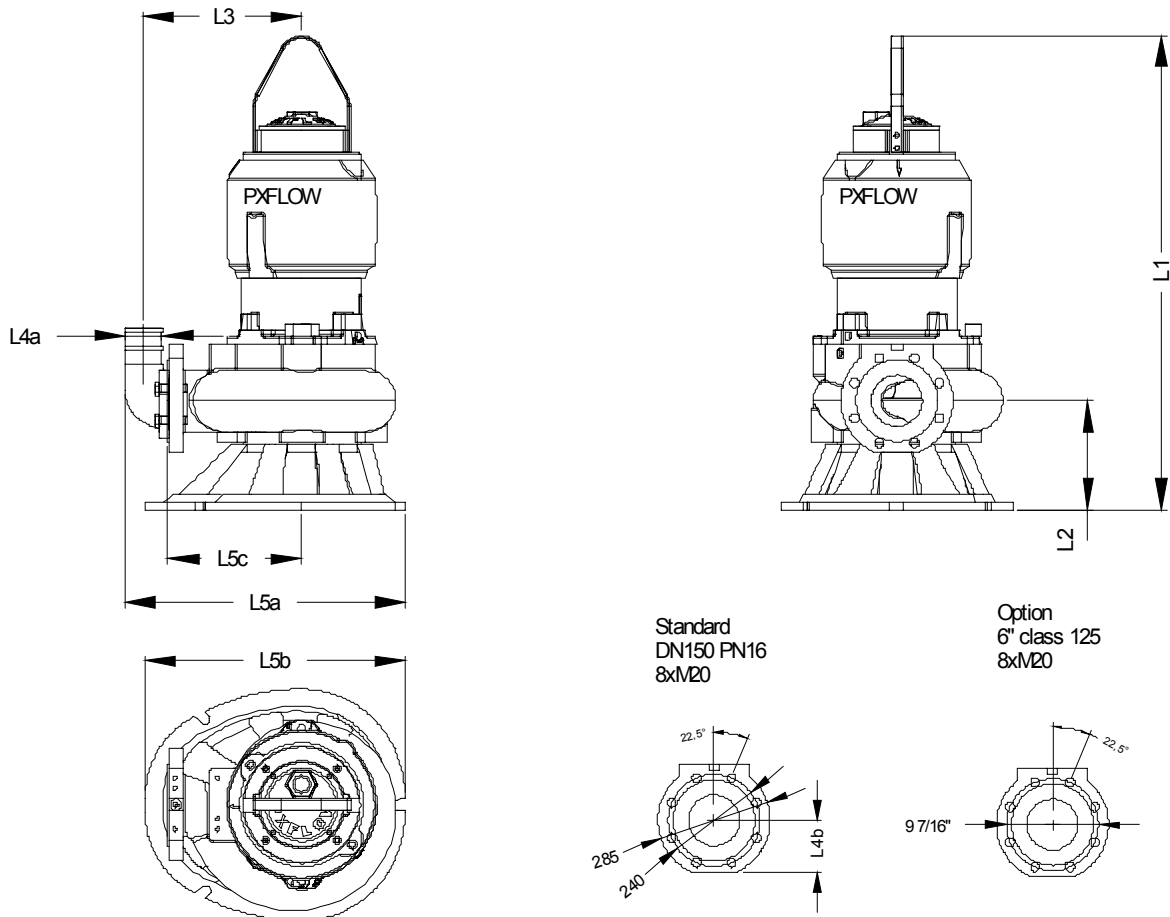

Standard
DN150 PN16
8xM20

Option
6" class 125
8xM20

Dimensions	mm	Dimensions	mm
L1	945		
L2	224		
L3	446		
L4a	150		
L4b	130		
L5a	752		
L5b	509		
L5c	355		

Outlet for hose - Option : Ø 150mm (6")

For pump :
 Outlet flange - Standard : DN150 / PN16
 - Option : 6" ANSI class 125

Suction flange - Standard : DN150 / PN16
 - Option : 6" ANSI class 125

Weight of Pump with cooling jacket = 181 kg
 (without cooling jacket : - 20 kg)
 Weight of Base for Transportable = 8,7 kg