

data referred to : Water, pure [100%] ; 20°C; 0,9983kg/dm<sup>3</sup>; 1,001mm<sup>2</sup>/s Tolerances acc. ISO 9906 Annex A

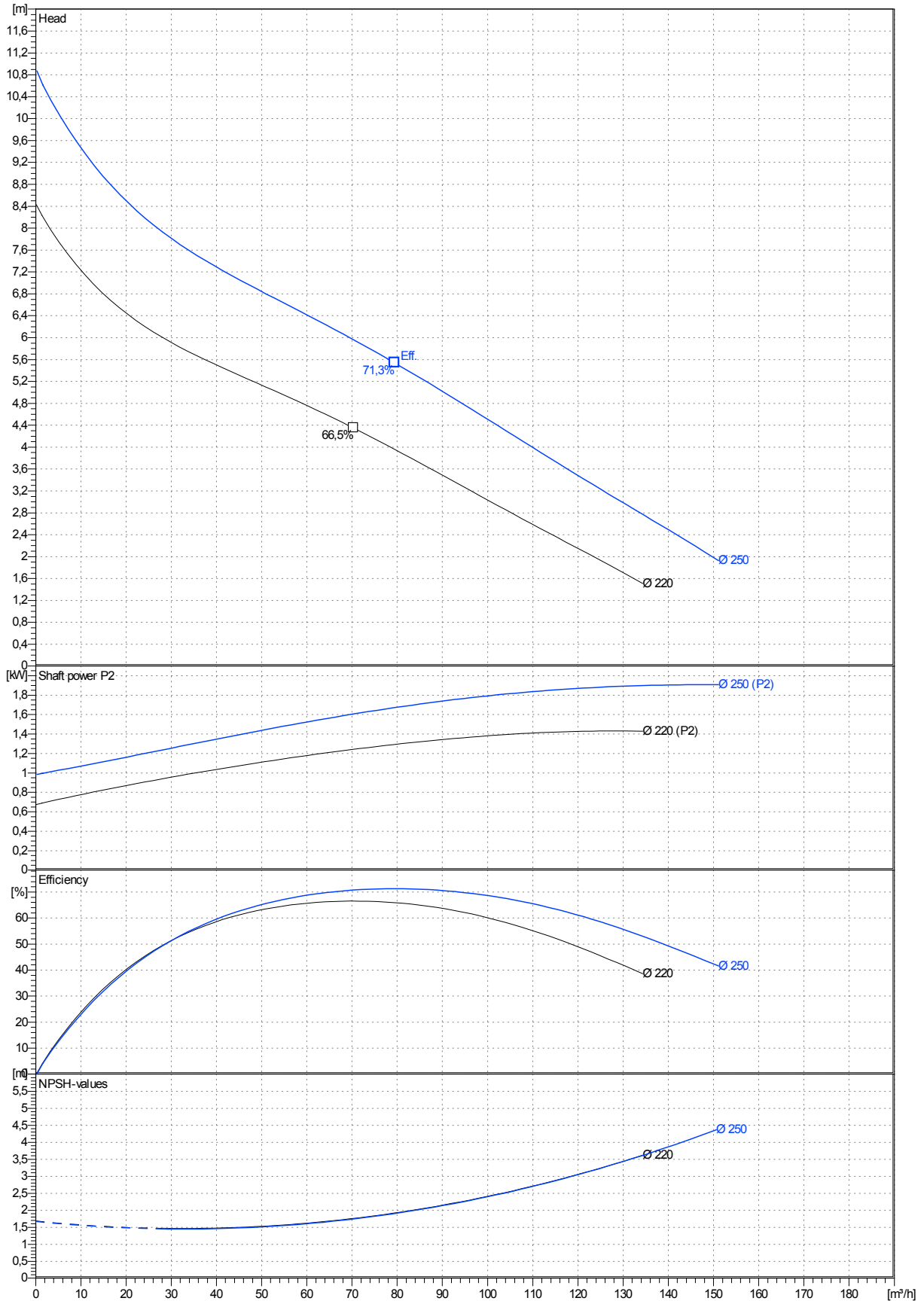

Curves are approximate, pump is guaranteed for one set of conditions (capacity, head, efficiency).  
PAPANTONATOS reserves the right to modify any data without prior notice.

Submersible, centrifugal, non-clogging sewage pump PX2-100.0-6 CHANNEL 1 capable of handling raw,unscreened sewage.

The pump can be capable of operating continuously in submersed or dry installed condition due the internal cooling system (standard version).

An internal impeller, fitted between the mechanical shaft seal, circulate a cooling liquid (Ecoflu) in a closed loop through a cooling jacket, and transfer the heat to the pumped liquid by a cooling flange (heat exchange).

The pumps manufactured within European Union with the latest manufacturing and environmental standards and practical standard features as :

-Electrical motor PXFLOW -SIEMENS with highest energy saving norm EFF1 have Class F insulation (rated for 155 degrees Celsius)as standard (Class H as option),three thermal overload switches, one per phase, internally wound to combat high temperature loads.

-Built-in moisture sensors

-Single channel impeller made in ductile iron GGG40 are of non clogging design

-Channel and vortex impellers can be accommodated in the same volute. This advance together with possibility to be trimmed allow to meet changing duties.

-Rotor shaft oversized made in stainless steel and oversized ball bearings ensuring smooth and vibration free running with extended life time as result.

-Shaft sealing system consist of double mechanical seals built into a replaceable cartridge facilitate quick changes even on-site without special tools.

-Wear rings with 'reducer' clearances system allow to be re-positioned axially in order to reduce the clearances between the channel impeller and volute.

-Fast lock connection system latch bolts made in stainless steel for easy removal of the motor together with impeller from the volute.

#### Materials

Motor housing, volute :cast iron GG -25

Impeller, adapter: ductile iron GGG40

Shaft, cartridge sleeve :stainless steel 431

Shaft seal:Media side sic/sic  
Cooling side sic/carbon

Bearings:upper:single row deep groove ball bearing  
lower: double angular contact ball bearing

### PX2-100.0-6 CHANNEL 1 with motor M2.1- 3,0 / 6

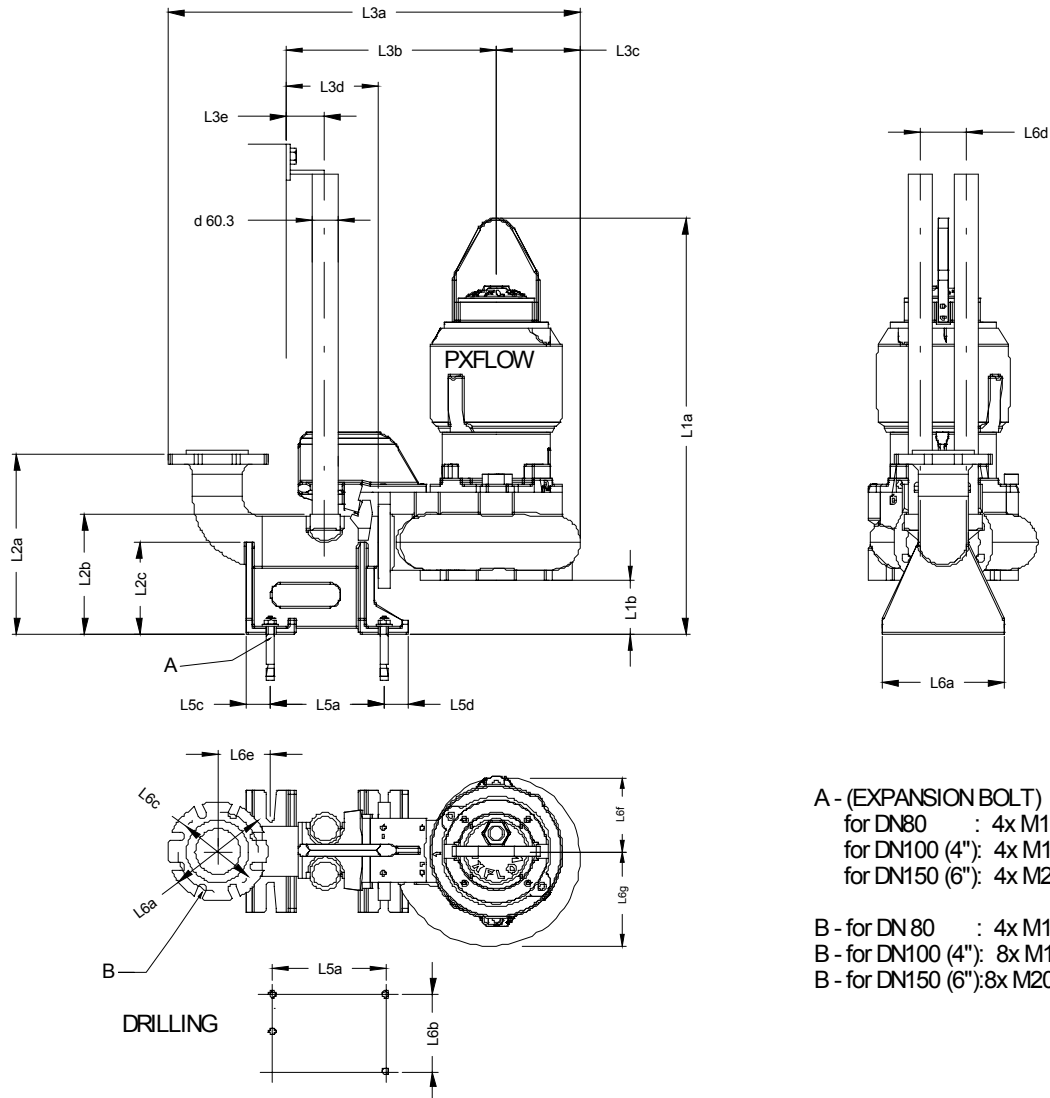

A - (EXPANSION BOLT)  
for DN80 : 4x M12x120  
for DN100 (4"): 4x M16x140 (5/8"x5.5")  
for DN150 (6"): 4x M20x200

B - for DN80 : 4x M16  
B - for DN100 (4"): 8x M16 (5/8")  
B - for DN150 (6"): 8x M20

Dimensions	mm	Dimensions	mm
L1a	908	L5d	60
L1b	112	L6a	270
L2a	405	L6b	220
L2b	265	L6c	180
L2c	200	L6d	100
L3a	915	L6e	112
L3b	470	L6f	178
L3c	195	L6g	211
L3d	205		
L3e	90		
L3f	355		
L5a	250		
L5b	170		
L5c	50		

For Discharge connection bracket :  
Outlet flange - Standard : DN100 / PN10  
- Option : 4" ANSI class 125

For pump :  
Outlet flange - Standard : DN100 / PN16  
- Option : 4" ANSI class 125

Suction flange - Standard : DN100 / PN16  
- Option : 4" ANSI class 125

Weight of Pump with cooling jacket = 140 kg  
( without cooling jacket : - 20 kg )  
Weight of Adapter = 10 kg

**PX2-100.0-6 CHANNEL 1 with motor M2.1- 3,0 / 6**

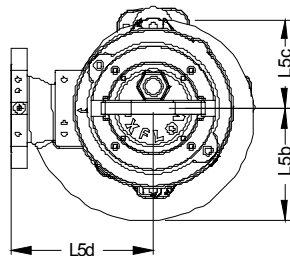
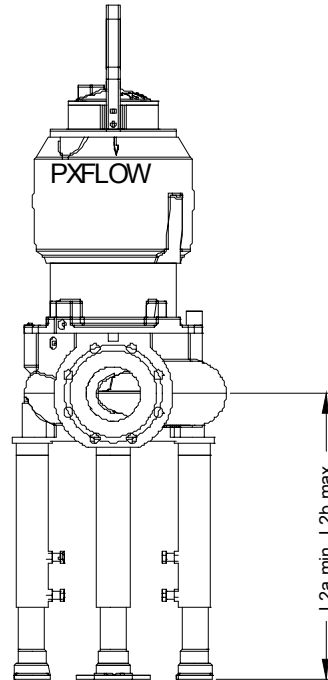
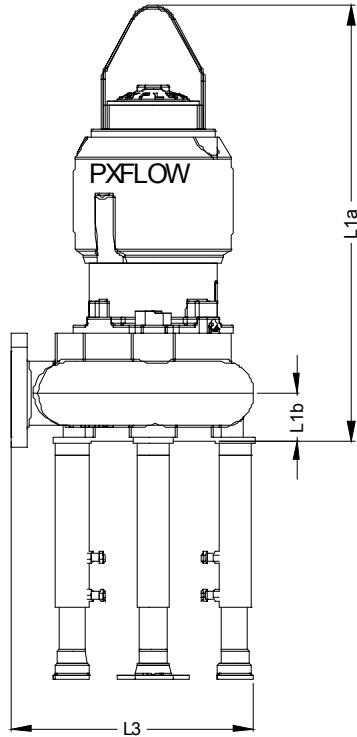

Standard  
DN100 PN16  
8xM16

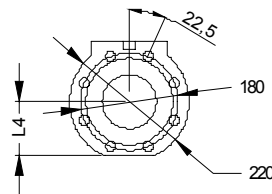

Option  
4" class 125  
8xM16

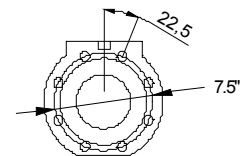

Dimensions	mm	Dimensions	mm
L1a	806		
L1b	88		
L2max	425		
L2min	290		
L3	507		
L4	103		
L5b	265		
L5c	180		
L5d	215		

Outlet flange - Standard : DN100 / PN16  
- Option : 4" ANSI class 125

Suction flange - Standard : DN100 / PN16  
- Option : 4" ANSI class 125

Weight of Pump with cooling jacket = 140 kg  
Weight of Adjustable Legs = 6,1 kg

**PX2-100.0-6 CHANNEL 1 with motor M2.1- 3,0 / 6**

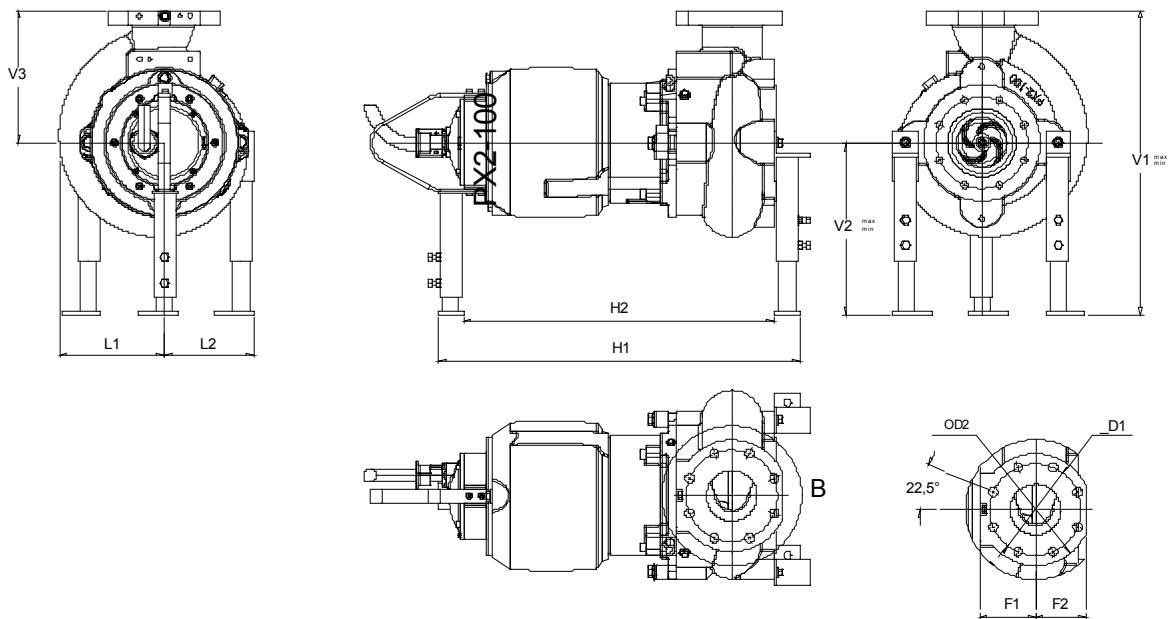

Dimensions	mm	Dimensions	mm
D1	180		
D2	220		
F1	125		
F2	103		
H1	630		
H2	750		
L1	210		
L2	180		
V1max	725		
V1min	590		
V2max	455		
V2min	320		
V3	270		

Outlet flange - Standard : DN100 / PN16  
- Option : 4" ANSI class 125

Suction flange - Standard : DN100 / PN16  
- Option : 4" ANSI class 125

Weight of Pump with cooling jacket = 140 kg  
Weight of Adjustable Legs = 0 kg

**PX2-100.0-6 CHANNEL 1 with motor M2.1- 3,0 / 6**

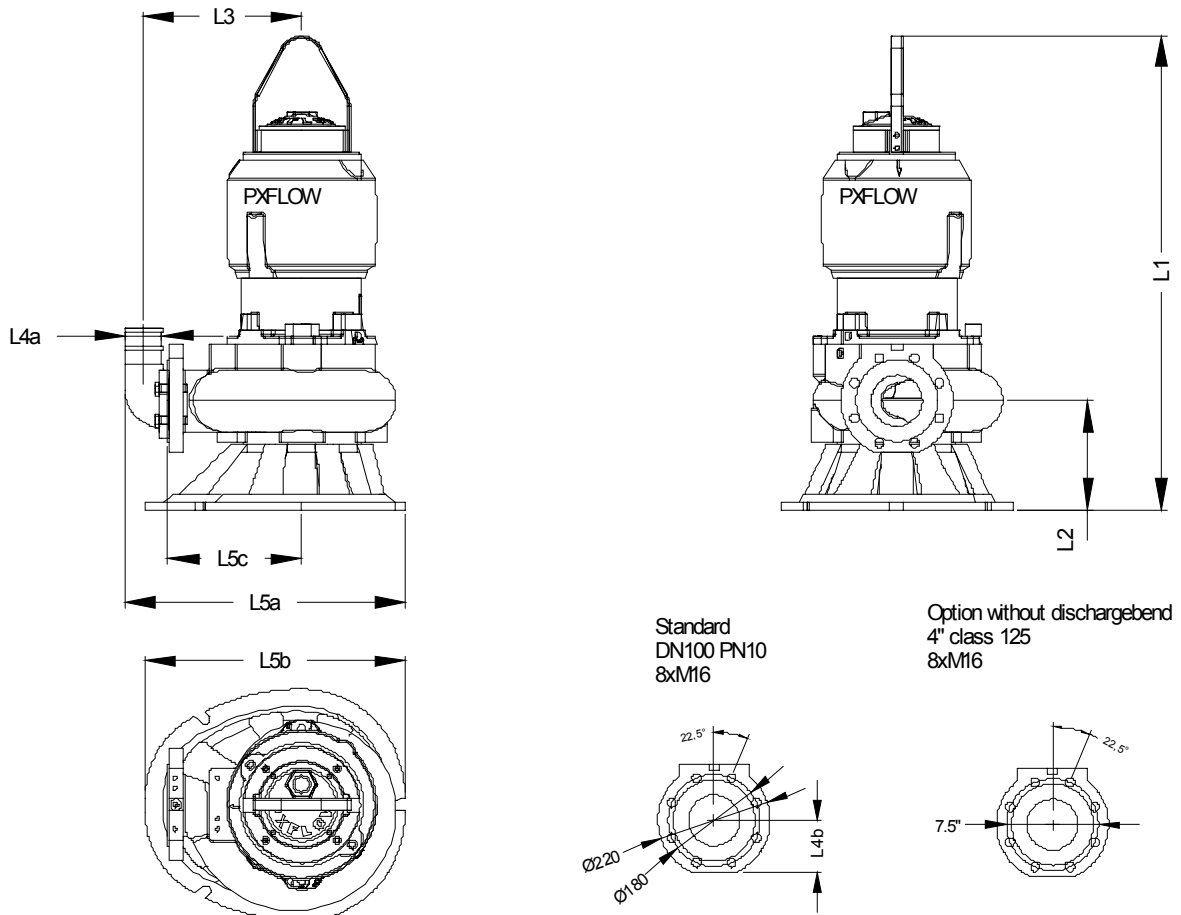

Standard  
DN100 PN10  
8xM16

Option without discharge bend  
4" class 125  
8xM16

Dimensions	mm	Dimensions	mm
L1	926		
L2	208		
L3	332		
L4a	100		
L4b	103		
L5a	633		
L5b	500		
L5c	265		

Outlet for hose - Option : Ø 100mm (4")

For pump :  
 Outlet flange - Standard : DN100 / PN16  
 - Option : 4" ANSI class 125

Suction flange - Standard : DN100 / PN16  
 - Option : 4" ANSI class 125

Weight of Pump with cooling jacket = 140 kg  
 ( without cooling jacket : - 20 kg )  
 Weight of Base for Transportable = 8,7 kg